

## Continuous LED lighting system for high and low bay applications

The latest member of the Visio family, the Visio Zip takes all of the features of our popular Visio and adds the benefit of fast installation using our pre-wired trunking system. With an efficiency of up to 166.7 luminaire lumens per circuit watt combined with four different optical distributions (Area Broad, Area Medium, Rack Narrow and Rack Medium), there is a solution for a wide range of applications.

The rolled galvanised steel trunking is supplied with a pre-installed wiring loom with plug and socket connections at regular intervals for reliable, error free, fast installation. SmartScan versions have a unique integral sensor that can be optimised for mounting heights up to 18m, maintaining excellent presence detection.

Applications: General open factory areas, storage, high-level racking aisles

- Four light distribution options
- Raw galvanised steel trunking
- Pre-installed wiring loom, module-sockets at 1500 mm intervals
- Plug and socket connections between trunking joints
- Luminaires click fit using stainless steel spring (requires a standard screwdriver to release)
- SmartScan wireless technology removes the need for control cabling. Ideal for retro-fit

Notes: Visio Zip is only compatible with the Visio Zip trunking range ordered separately. See installation guide for mounting point locations.



IP20

IK07

Up to 166.7 LL/CW

### Specification

Mounting	Surface Suspended	IP rating	IP20
Impact rating	IK07	Nominal size	800 mm 1400 mm
Max presence detection height	18 m		

### Lighting

Lumen output	17,460 lm - 36,150 lm	Efficacy	Up to 166.7 LL/CW
--------------	-----------------------	----------	-------------------

---

## Emergency data

Emergency lumen output	970 lm - 1,090 lm	Emergency type	Maintained
Emergency duration	3 hours	Battery specification	Nickel Metal Hydride (NiMH)

---

## Power

LED power	101 W - 212 W	Circuit power	110 W - 217 W
-----------	---------------	---------------	---------------

---

## LED characteristics

CRI	80+	Colour temperature	4000 K
Rated life (hours)	100 K - L70/B10		

---

## Compliance

UKCA	Yes	CE	Yes
------	-----	----	-----

## Dimensions

### Standard and Smart

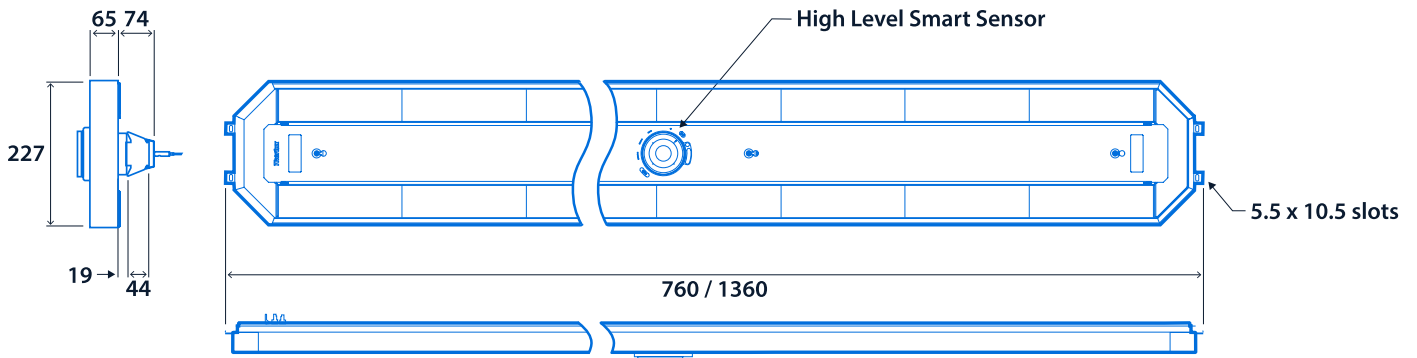

### Emergency

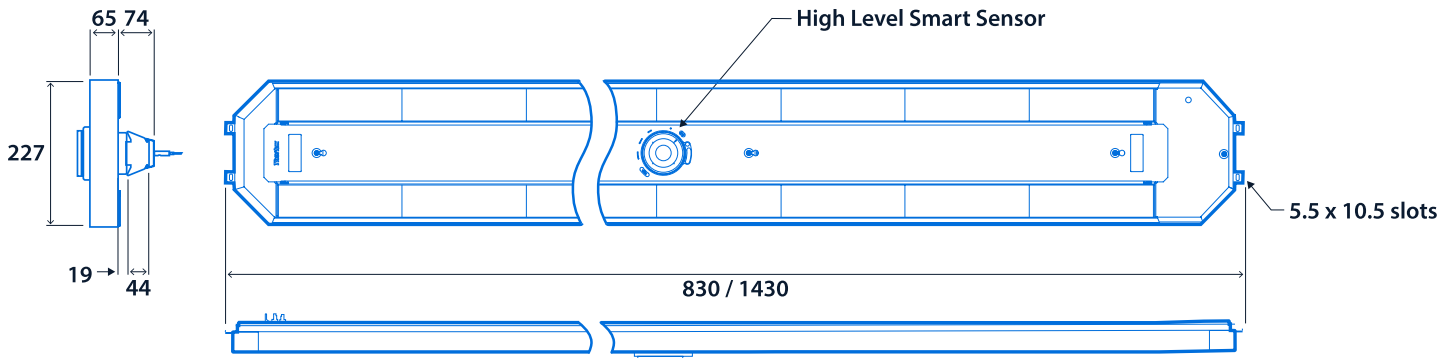

### End kit

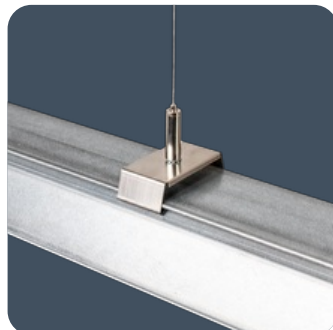
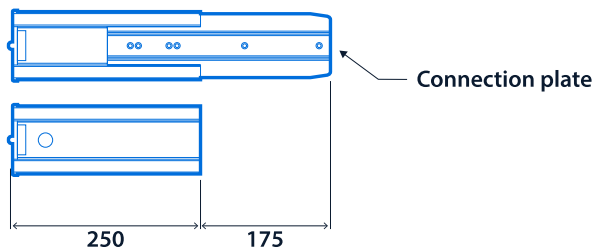

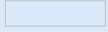

## Click or scan here

View Visio Zip variants using  
our online filtering tool



Information is correct as of 12 Mar 2025, however must not be interpreted as a guarantee of individual product performance and/or characteristics. We reserve the right to alter specifications and designs without prior notice.